

OPERATIONS AND MAINTENANCE MANUAL WIRELINE WINCH OPERATORS PANEL

**AMS4A062 – Differential Load Pin
AMS4A063 – 2 mv/v Load Pin
AMS4A064 – 4-20ma Load Pin**

TABLE OF CONTENTS

SECTION	DESCRIPTION
1.0	GENERAL DESCRIPTION
2.0	DETAILED DESCRIPTION OF FEATURES
3.0	MENU OPERATING INSTRUCTIONS
4.0	SYSTEM OPERATING INSTRUCTIONS
5.0	PANEL PARTS LIST
6.0	DRAWINGS AND SETUP PROCEDURES
7.0	CABLE DRAWINGS AND PARTS LISTS

1.0 INTRODUCTION

1.1 GENERAL DESCRIPTION



This panel is designed to acquire and display depth and tension from a wireline winch unit. The panel uses a menu system to set and make adjustments to the data as necessary.

When first powered up, each of the menu settings are displayed on the depth and line speed displays.

Depth is displayed from data provided from an encoder mounted on a measuring device. The tension data is provided by a load pin. Depth and tension data can be stored in an internal memory board for playback at a later time. The panel can also be connected to a PC through a serial port for real time acquisition and playback of data.

The system is designed to operate properly from conventional automotive 12-24 vdc electrical power.

Loss of power to the panel during operation will not cause a loss of depth data. The panel continuously stores depth data every 100 milliseconds in an internal battery backed up memory device. When power is applied, the last "Depth" is displayed.

The
to be mounted



panel is designed
in a hoist console

Or on a bracket that allows to panel to be mounted overhead or against a wall.



1.2 FEATURES AND SPECIFICATIONS

- Digital displays for depth, line speed and tension
- Analog tension meters, 4 inch (108 mm) dia., 270 degree
- Excessive tension alarm setting allows operator to set tension alarm to a predetermined value. Contact closure is provided for winch shutdown
- Zero Depth button - sets depth to 0. Depressing button again resets depth to previous setting. Only works when line speed is zero
- Approaching surface alarm
- Depth adjust up or down switches. Only works when winch is stopped
- Load pin zero & calibrate controls. Only works when there is no load on the cable and the depth is at zero.
- Depth & tension saved in non-volatile memory at power loss
- RS232 Interface for additional control and data outputs.
- Can be set to display either English or Metric units.
- Data recorder which records both depth and tension data to a solid state memory device

1.3 SPECIFICATIONS

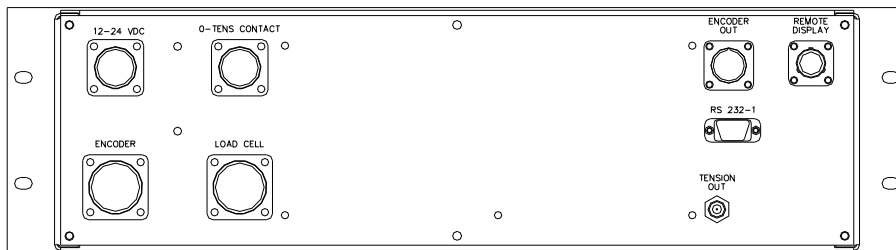
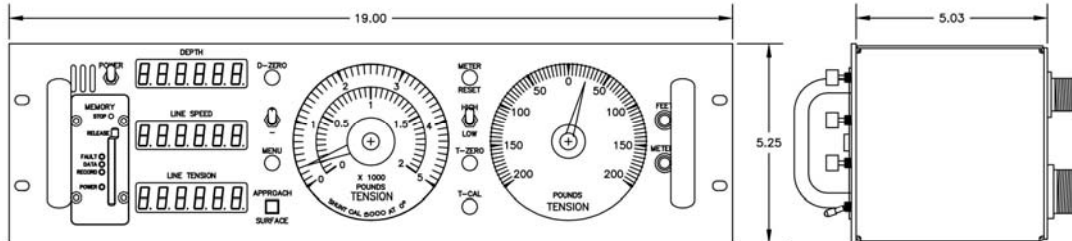

1.3.1	TEMPERATURE RATING	-20 to 140
1.3.2	POWER SUPPLY	9 – 30 VDC @ 2 AMP MAX
1.3.3	MAXIMUM LINE SPEED	3000 FT/MIN @ 600 PULSES/FT
1.3.4	MINIMUM LINE SPEED	.6 FT / MINUTE
1.3.5	MAXIMUM LINE TENSION	8000 LBS
1.3.6	DIGITAL TENSION	6 DIGITS WITH 1 LB OR 1KG RESOLUTION
1.3.7	DIGITAL LINE SPEED	6 DIGITS WITH .1 FT OR .1 M RESOLUTION

2.0 DETAILED DESCRIPTION OF FEATURES

2.1 FRONT PANEL

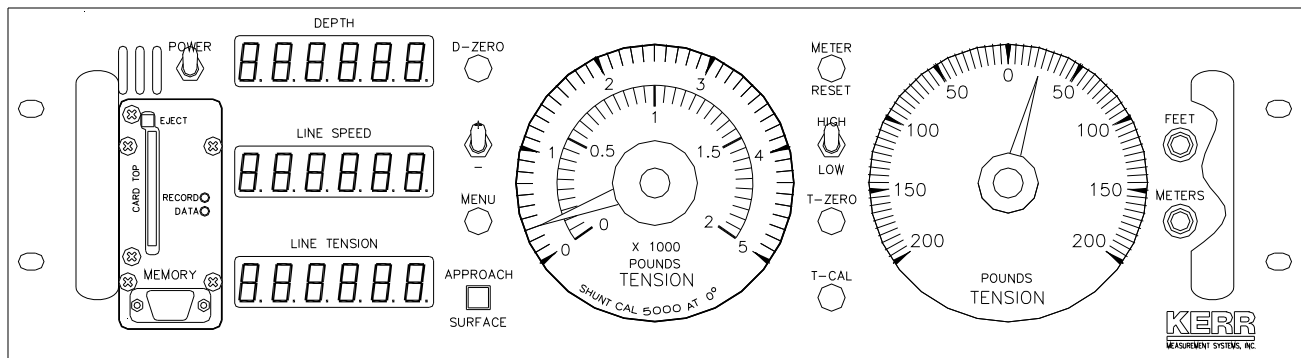

2.1.1 POWER ON / OFF SWITCH

This switch turns the panel on (UP position) or also starts the automatic shutdown process (DOWN position). There is a built in delay when powering down which gives the system time to close the media card data files. After the files are closed, the panel will turn itself off.

2.1.2 ANALOG INCREMENTAL TENSION METER

This meter displays incremental tension. This provides a more visual display of tension change.

Incremental tension provides a high resolution tension scale. It must be periodically reset as tension increases or decreases to keep the needle centered.

2.1.3 METER RESET SWITCH

This switch will reset the incremental tension meter to the 0 (center) position.

2.1.4 ANALOG TENSION METER

This meter displays total tension. This provides a visual display of tension which corresponds to the digital tension meter.

This meter is dual scale. A switch is provided to change scales.

If the switch is set to HIGH the outer scale (0-5000 pound) is used.
If the switch is set to LOW the inner scale (0-2000 pound) is used.

Note: Analog meter faces are available with kg increments.

2.1.5 DEPTH DISPLAY

This meter provides a digital display of depth.

2.1.6 LINE SPEED DISPLAY

This meter provides a digital display of line speed. It can be set in feet or meters per minute or per hour.

2.1.7 LINE TENSION DISPLAY

This meter provides a digital display of total line tension.

2.1.8 ZERO DEPTH

Pressing this button will reset the depth to 0. Pressing the button again will reset the depth to the previous setting. The Zero Depth button will only work when the line speed is zero (i.e. winch not moving). If depth is not at zero you cannot calibrate tension.

2.1.9 + / - SWITCH

This switch is used for different functions. It is used to change the depth setting in either an up or down direction. The winch must be stopped before the depth can be set. In menu mode (see section 3.0) the switch is used to set menu parameters.

2.1.10 MENU

Pressing this button will activate the menu software. The software feature to be set will be displayed on the DEPTH display. The features can be toggled through by pressing the menu button until the desired feature is displayed.

2.1.11 APPROACHING SURFACE LED AND ALARM

This LED is lit and an audible alarm is sounded when the depth is less than 100' (30 m). This is a warning to the hoist operator that they are approaching surface and should take care to get the equipment safely out of the well. When the LED is depressed, the alarm will stop but the LED will continue to blink. Once the depth reading is greater than 100' (30 m), both the alarm and the LED will turn off.

2.1.12 ENGLISH / METRIC UNITS

These LEDs will indicate if the panel is in English or metric mode. If units are set to English, the English LED will be lit. If units are set to Metric the Metric LED will be lit.

2.1.13 T-ZERO SWITCH

Use this switch to set the tension to 0 at the start of a run. This will zero out the tension circuit. The line should be slack through the head at this time. Depth must be at zero before this switch and the T-CAL switch will function.

2.1.14 T-CAL SWITCH

This switch will activate the shunt cal circuit in the load pin. 4000 lb will be displayed on the tension display if it is set for the Shark measuring head. 5000 lb will be displayed if the panel is set for MegaMouth or AM3K. 10000 lb will be displayed if the panel is set for AM5K or MAKO.

Refer to section 6.8.3 for more information.

2.1.15 PROCESSOR REBOOT

In the event of a panel "lock up" or other malfunction, the processor in the panel can be rebooted by turning off the panel, depressing the T-ZERO and T-CAL buttons simultaneously then turn the power back on while the buttons are depressed. Keep the buttons depressed for at least 5 seconds after power is restored.

When the panel is rebooted, all the menu settings will be returned to the factory default settings. The panel should always be rebooted

after new software (eprom) has been installed.

2.2 REAR PANEL

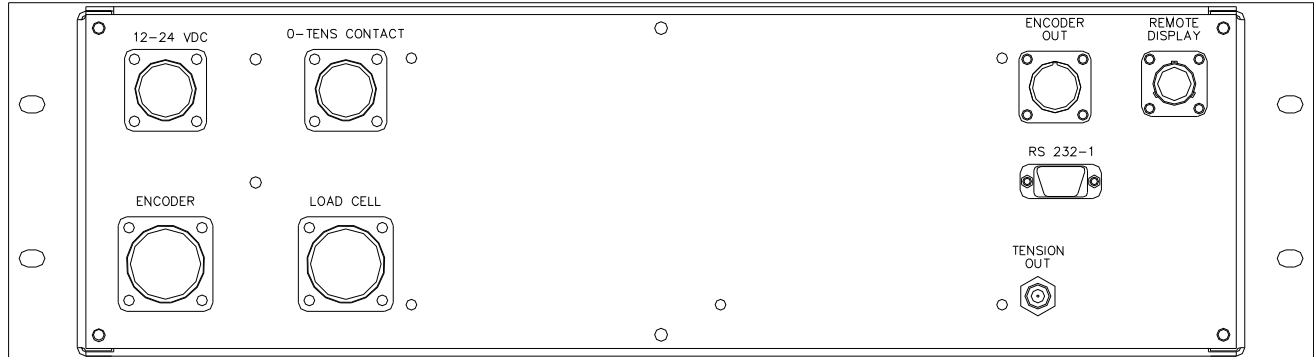

2.2.1 12 – 24 VDC

This connector supplies dc power for the panel operation (9 VDC min, 30 VDC max). The panel can operate on either 12 or 24 vdc (12 vdc is U.S. truck standard voltage, 24vdc is European truck standard voltage). Pin A is positive (white wire), pin B is negative (black wire).

2.2.2 OVER TENSION CONTACT

This connector provides a connection to the overtension circuit relay. When an overtension condition is active, the two pins are connected together. In normal position the two pins are open. This feature can be used to interface to the winch unit control system to provide automatic hoist shutdown when an overtension condition is reached.

2.2.3 ENCODER IN

The cable running from the encoder on the measuring head attaches to this connector. From this connector, the panel provides 12 vdc power to the encoder and accepts the encoder quadrature signal input. It is designed to work with standard encoders.

2.2.4 LOAD CELL

This connector is used to connect to the load pin. The panel provides +/-15VDC power to the load pin and gets the tension signal input from this connector

2.2.5 REMOTE DISPLAY

This connector provides an interface to a remote display/pressure display system. The connector provides power, depth, and tension information to the remote unit and reads pressure data from the remote unit. This pressure data can be stored on the internal data recorder and also appended to the end of the D string at the RS232 output.

2.2.6 ENCODER OUTPUT

This connector provides an encoder quadrature output signal. This signal can be used to drive a computer system without requiring a second encoder to be installed on the measuring head. The encoder output signal includes all the corrections made by the panel such as wire and wheel size, stretch correction, shim, etc.

2.2.7 TENSION OUTPUT

This connector provides a tension output signal. This signal can be used to record pressure on a computer system. The signal output can be configured for either 4-20ma output or a 0-10vdc output.

2.2.8 RS232 SERIAL INTERFACE

This connector provides an RS232 interface from the panel to an external computer. A PC can be used to display depth, tension, and line speed data from the panel. The PC can also be used to set panel parameters.

To connect the panel to a computer, connect a serial cable from the PC to J6 on the rear of the panel. A program is available from Benchmark Wireline Products to display this data (see figure below).

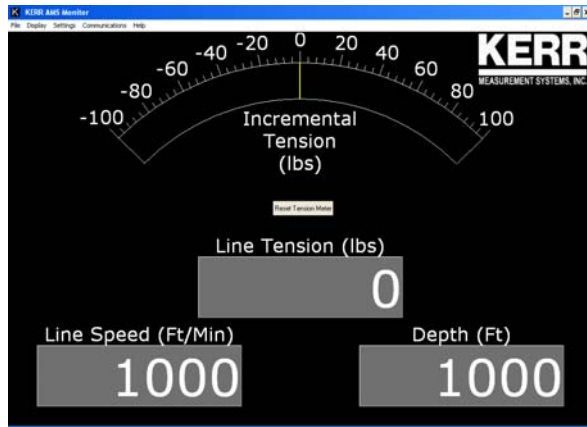

3.0 MENU COMMANDS

This panel has internal software which allows it to be set for various configurations. To change the settings, press the MENU button. The feature to be set will be displayed on the DEPTH display. Press the MENU button again until the feature you want to set is displayed.

The parameters for each feature will be displayed on the LINE SPEED display. Press the +/- switch to cycle through all the available parameters. When the value you want to select is displayed, press the MENU button. ACCEPT will then be displayed. Press + for yes, - for no. Following is a listing of all the available settings.

3.1 TEN ALARM

When value is reached an alarm sounds and the tension contact closure switch is closed. This can be used to provide a signal to automatically stop the winch.

Procedure: Use +/- switch to set the tension alarm setting. **This setting does not need to be accepted when changed.**

TALARM will be displayed on the DEPTH display (top) and the value will be displayed on the LINE SPEED display (center) as it is being set. Default value is 300 lbs

DATA RECORDER OPTION

Either **RECALL** (Record All data) or **RECNEW** (Record only New data) will be displayed on the TENSION display (bottom).

If this option is set to **RECALL**, data will be written to the flash card and front serial port continuously (1 x per second).

If the panel is set to **RECNEW** then only new data will be written. New data is defined as when depth is changed by more than 0.1' or when tension changes by more than 10 pounds. Interpolation can be used to fill in non written records since a DATE and TIME stamp is recorded as a part of each data record.

Use the **approaching surface** button to toggle the Data Recorder setting between **RECALL** and **RECNEW**.

Default value is **RECNEW**.

3.2 LINE SIZE

Line size selection in conjunction with the wheel size sets the wheel circumference value. The depth must be at 0 before this setting can be changed.

Use +/- switch to select line size.

LINESZ will be displayed on the DEPTH display and the selections will be displayed on the LINE SPEED display.

Line Size Values available for SHARK OR MEGAMOUTH

.092
.108 (default setting)
.125
3-16
OTHER

Line Size Values available for MAKO

.092
.108 (default setting)
.125
.140
.150
.160
3-16
7-32
5-16
OTHER

When OTHER is selected, the wireline weight and stretch coefficient can be entered at this time. This data should be available for the manufacturers wireline data sheet.

Line Size Values available – AM3K HEAD

3-16
7-32
1/4
9-32
5-16 – (default setting)
3-8

Line Size Values available – AM5K HEAD

3-16
7-32
1/4
9-32
5-16 – (default setting)
3-8
7-16
15-32
.472 – HT
.484 – HT
.492 - HT

Note: HT = High Tension and should only be used with the deep grooved tension wheel.

3.3 DEPTH ALARM

When depth alarm value is reached, the alarm will sound and LED will flash. Pressing the LED will turn off alarm but the light will continue to flash. The light is reset whenever the depth zero button is depressed.

Use +/- switch to set the depth alarm value.

DALARM will be displayed on the DEPTH display and the value will be displayed on the LINE SPEED display as it is being set.

Default value is 100'

3.4 DEPTH ADJUST (Shim)

This parameter is used to correct depth readings for situations such as extremely worn measurement wheels.

The amount selected will automatically be added or subtracted from the depth input.

Use +/- switch to set the DEPTH ADJUST setting.

DP-ADJ will be displayed on the DEPTH display and the value will be displayed on the LINE SPEED display as it is being set. The values are feet / thousand or meters / thousand. The smallest increment is .1 foot per thousand.



Default value is 0.

3.5 ENCODER DIR

This command will set the encoder direction to UP or Down.

Use +/- switch to toggle the ENCODER direction setting.

ENCDIR will be displayed on the **DEPTH** display and either **UP** or **DN** will be displayed on the **LINE SPEED** display.

Default value is **DN**.

3.6 ENCODER PULSES PER REVOLUTION

The value selected will automatically be used as the encoder input pulses per revolution (PPR) setting.

Use +/- switch to set the ENCODER Pulse Per Revolution setting.

EN-PPR will be displayed on the DEPTH display and the value will be displayed on the LINE SPEED display as it is being set.

Default value is 1200.

3.7 ENCODER OUTPUT

The value selected is the encoder out Pulse Per Foot setting.

Use +/- switch to set the ENCODER Output setting.

EN-OUT will be displayed on the DEPTH display and the value will be displayed on the LINE SPEED display as it is being set.

Default value is 600.

3.8 LINE SPEED

This command will set the line speed to either feet/meters per minute of feet/meters per hour.

Use +/- switch to toggle the LINE SPEED setting.

LSPEED will be displayed on the DEPTH display and either **MIN** or **HOUR** will be displayed on the LINE SPEED display.

Default value is MIN.

3.9 STRETCH CORRECTION

This command will turn the STRETCH CORRECTION setting ON or OFF.

Use +/- switch to toggle between ON and OFF.

D-CORR will be displayed on the DEPTH display and either ON or OFF will be displayed on the LINE SPEED display.

Default value is ON.

Stretch is calculated by stretch due to cable weight + stretch due to weight at end of cable

$$\text{stretch due to cable weight} = \text{stretch coefficient} * \text{depth} * \text{cable weight} / 2$$

$$\text{stretch due to weight at end of cable} = \text{stretch coefficient} * \text{depth} * (\text{tension} - \text{cable weight})$$

When tension is less than cable weight, tension measured is due to cable weight alone.

3.10 DEPTH UNITS

The depth values will be displayed in the units selected.

Use +/- switch to set the DEPTH UNITS setting.

DEPTH will be displayed on the DEPTH display. The selection can be toggled between FEET or METERS. The selection will be displayed on the TENSION display. The ENGLISH (green) LED display will be lit when FEET is selected and the METRIC (red) LED will be lit when METERS is selected.

3.11 TENSION UNITS

The tension value will be displayed in the units selected.

Use +/- switch to set the TENSION UNITS setting.

TENSION will be displayed on the DEPTH display. The selection can be toggled between POUNDS and KILOGM. The selection will be displayed on the TENSION display.

Note: Analog meter faces are available with kg increments.

3.12 PRESSURE

This option controls the optional pressure display (if connected). If Y is selected, the following options are available.

PRESS1

Selecting **N** will blank the PRESS 1 display.

PRESS2

Selecting **N** will blank the PRESS 2 display.

ZEROP1

Selecting **Y** will set the PRESS 1 display to 0 (if the transducer is connected to the PRESS 1 input). This should be performed when no pressure is applied to the transducer.

ZEROP2

Selecting **Y** will set the PRESS 2 display to 0 (if the transducer is connected to the PRESS 2 input). This should be performed when no pressure is applied to the transducer.

REC_PR

Selecting **Y** will append the pressure data to the internal data recorder.

SER_PR

Selecting **Y** will append the pressure data to the end of the D string. This data will then be available at the rear serial port

3.13 HEAD TYPE

Five options are available:

SHARK	SHARK SLICK LINE HEAD
MMOUTH	MEGAMOUTH or HAMMERHEAD SLICK LINE / BRAIDED LINE HEAD
MAKO	MAKO SLICK LINE / BRAIDED LINE HEAD
3K	AM3K BRAIDED LINE / E LINE HEAD
5K	AM5K BRAIDED LINE / E LINE HEAD
OTHER	

This selection determines the tension scale and tension K factor.

SHARK:	1.5V = 4000 LBS
MEGAMOUTH:	1.5V = 9000 LBS
MAKO:	1.5V = 10000 LBS

AM3K =	3/16"	1.45
	7/32"	1.38
	1/4"	1.22
	9/32"	1.08
	5/16"	1.00
	3/8"	.85

AM5K =	15/32" and >	1.00
	7/16"	1.10
	5/16"	1.42
	9/32"	1.48
	1/4"	1.68
	7/32"	1.88

This selection also determines the measuring wheel size used in depth calculation.

MEGAMOUTH AND SHARK = 15.153 INCHES DIA.

MAKO = 20.0593 INCHES DIA.

Wheel size circumference with wireline installed is calculated by:
 $(\text{Wheel dia.} + \text{Line dia.} \cdot 108) \cdot \pi$

Example: Shark with .125 wireline:
 $(15.153" + .125) \cdot \pi = 47.997$ inches circumference

AM3K = 7.639" (194 mm) diameter wheel (2.0' circumference)
+ line diameter + cable factor

3/16" cable – 2.015 ft

7/32" cable - 2.017 ft.

1/4" cable – 2.020 ft.

9/32" cable – 2.023 ft.

5/16" cable - 2.026 ft.

3/8" cable – 2.031 ft.

AM5K = 7.639" (194 mm) diameter wheel (2.0' circumference)

OTHER

When OTHER is selected the WHLCIR can be entered to change the circumference of the measuring wheel. This option allows the panel to be set for a measuring head that uses different sized measuring wheels. Data entered is in feet.

The wheel size will be forced to this value regardless of wireline size selections.

The default value is 1.00 ft.

3.15 DBOOST

The differential tension meter can be set to respond quicker to a tension change. A quicker response may help in seeing small or quick tension changes such as when Jars open.

If the boost is set too high the meter may be too sensitive (jittery).

This commands sets the sensitivity of the differential tension meter (Differential Boost) where 0 = no boost and 5 = maximum boost.

4.0 SYSTEM OPERATING INSTRUCTIONS

4.1 WELLSITE OPERATION

- 4.1.1 Power up panel and verify it is working properly.
- 4.1.2 Verify the panel is configured to match the system
 - Line size
 - Measurement units
 - Encoder settings
- 4.1.3 Install line in measuring head and set the line size parameter.
- 4.1.4 Set Tension Alarm value.
- 4.1.5 Set depth adjust value if necessary.
- 4.1.6 Ensure that memory card is installed in data recorder. Turn power to panel off then on again. This will write the operating parameters to the memory card.
- 4.1.7 Rig up through sheaves, install tool, and slack off weight.
- 4.1.8 Set depth to zero.
- 4.1.9 Press T-Zero to set tension to zero.
- 4.1.10 Press T-CAL and verify that panel tension reads 4000 or 5000 lbs (depending on type of measuring head selected)
- 4.1.11 Pull tool to depth 0 position. Press D-Zero to reset the panel depth to 0.

4.2 INTERNAL DATA RECORDER OPERATION

This device records depth and tension data along with other job parameters onto a compact flash card.

4.2.1 DATA FORMAT

Data is stored as:

DATE (mm/dd/yy)

TIME (hhmmss.ss)

UNITS (E=English, M=Metric)

DIRECTION (U=Up, D=Down, S=Stopped)

DEPTH nnnnn.n

SPEED nnnn.n

TENSION nnnnnn

PRESSURE 1 nnnn (if REC_PR is enabled – refer to page 16)

PRESSURE 2 nnnn (if REC_PR is enabled – refer to page 16)

<CR> - CARRIAGE RETURN, <LF> - LINEFEED

See following example

```

20091202 151415.00 E S + 41.7 0.0 2317
20091202 151416.00 E S + 42.7 0.0 2317
20091202 151417.00 E S + 43.7 0.0 2317
20091202 151418.00 E S + 44.7 0.0 2317
20091202 151419.00 E S + 45.7 0.0 2317
20091202 151420.00 E S + 52.1 0.0 2317
20091202 151555.00 E S + 57.1 0.0 2317
20091202 151556.00 E S + 57.6 0.0 2317 0 0
20091202 151557.00 E S + 57.7 0.0 2317 0 0
20091202 151558.00 E S + 58.7 0.0 2317 0 0
20091202 151559.00 E S + 59.7 0.0 2317 0 0
20091202 151600.00 E S + 60.7 0.0 2317 0 0
20091202 151601.00 E S + 61.7 0.0 2317 0 0
20091202 151616.00 E S + 64.7 0.0 2317 0 0
20091202 151625.00 E S + 0.0 0.0 2317 0 0
20091202 151626.00 E S + 0.8 0.0 2317 0 0
20091202 151627.00 E S + 1.2 0.0 2317 0 0

```

4.2.2 DATA RECORD

Data is written to the board 1 time per second. Data is stored in

ASCII TEXT format. Each line terminates with CR and LF characters.

To minimize the amount of data written to the board, the panel can be set (see 3.1) to write data only when depth is changed by more than 0.1' or when tension changes by more than 10 pounds. Interpolation can be used to fill in non written records since a DATE and TIME stamp is recorded as a part of each data record.

The panel can also be set to write data continuously so that no interpolation is necessary. This is recommend when if you want to correlate surface depth and tension readings with memory gauge readings.

The RECORD LED on the front of the DATA RECORDER board indicates that it is in RECORD mode.

The DATA LED flashes each time a data record is written.

Before removing the CompactFlash card, turn the panel power off. There is a delay when turning off the power while the data files are being closed. After a short delay, the panel will power itself off.

To continue recording on a new flash card, insert the card then turn the panel off then on. This will put the panel into record mode and write a new header file on the CompactFlash card.

4.2.3 DATA EXPORT

The memory board can be removed and data moved onto a PC using a standard CompactFlash Media Reader. The data can be imported into programs such as MS Excel or MS Access.

To remove the compact flash card, Press the release button to eject the flash card.

4.2.4 MEDIA CARD

The CompactFlash media device used in the data recorder may be ordered using part number AMS4P232. Additionally it may be acquired from any number of other retail sources. 2 GB is the minimum recommended size.

4.2.5 SETTING RECORDER PARAMETERS

To set the parameters, connect a serial cable to the DB9 port on the front of the panel. The wiring is as follows:

DB9 PIN OUT: 2 = TRANSMIT, 3 = RECEIVE, 5 = GROUND

Run a program such as MS Windows HyperTerm using the following parameters

BAUD	19,200
BITS	8
PARITY	N
STOP	1
HANDSHAKING	NONE

When everything is set up, turn the panel power off then back on. At this time you will be given the opportunity to set the parameters by pressing any key. If no key stroke is detected during the panel bootup process the data recorder will enter the record mode.

In record mode, the same data that is written onto the CF card will also be written to the serial port.

If a keystroke is detected, you will be prompted to enter the unit number. This number can represent the hoist unit or well or other designator. The previously entered unit number will be displayed and if a new number is not entered it will remain.

Next you will be prompted to enter s to set time or rtn to keep the current time. If s is pressed:

Enter the day: 1 – 7 where 1 = Sun and 7 = Sat

To set the year, first enter the tens digit then enter the ones digit (i.e. for 2006 first enter 0 then 6).

To set the month, first enter the tens digit then enter the ones digit (i.e. for Dec. first enter 1 then 2, for Jan. first enter 0 then 1).

To set the day, first enter the tens digit then enter the ones digit (i.e. for the 15th first enter 1 then 5, for the 5th first enter 0 then 5).

To set the hours (24 hour format), enter 0 for 12:00AM to 9:00, 1 for 10:00 to 19:00, 2 for 20:00 to 23:00. Next enter actual hour (i.e. to set the hour to 17:00 first enter 1 then next enter 7, to set the hour to 09:00 first enter 0 then next enter 9).

To set the minutes, first enter the tens digit then enter the ones digit (i.e. for 21 minutes past the hour first enter 2 then 1, for 9 minutes past the hour first enter 0 then 9).

Seconds are set in the same manner.

At this time the system is ready to record data.

4.3 PANEL CONTROL AND OPERATION USING RS232 SERIAL PORT

To connect the panel to a computer, connect a serial cable from the PC to J6 on the rear of the panel. The wiring is as follows:

DB9 PIN OUT: 2 = TRANSMIT, 3 = RECEIVE, 5 = GROUND

Run a program such as MS Windows HyperTerm using the following parameters

BAUD	38,400
BITS	8
PARITY	N
STOP	1
HANDSHAKING	NONE

Type H to get the following help screen

*** AMS4A06X Help Screen ***

```

H,? - This screen.
D - Display units, direction, depth, speed, and tension.
P - Modify encoder pulses/revolution. Usage: P600
V - Verify AMS4A063 status.
Z - Preset depth.Usage: Z0.0 | _ | --> New depth.
A - Depth Alarm. Usage: A100 | _ | --> Depth Alarm.
W - Wheel Size.
N - Line Size N0 .092; N1 .108; N2 .125; N3 3/16;
    N4 7/32; N5 5/16
U - Modify units of measure
    F(feet);UM(meters);UP(pounds);UK(kg)
M - Tension Alarm. Usage: 'M2500' for 2500 pound alarm.
J - Depth Adjust. Usage: 'J-1' for -1 ft per 1000 feet
X - Encoder Direction. X+ or X-
0 - Tension Zero Cal
T - Tension Shunt Cal
  
```

- I - Enable/Disable Stretch Correction
- R - Toggles data recorder on or off
- # - Set the serial number of the panel. Usage #n

Type V to get the following verification screen

```

* * * AMS4A06X Setup Status * * *

Load Cell Angle-Factor      1.000
Wheel Size:                  4'
Encoder PPR:                 600
Line size =                  .108
Serial Number =              1
Units =                      English
Depth_adjust =               0.0
Linespeed =                  0
Tension Alarm =              2500
Depth Alarm =                100
Data Recorder is            ON
Stretch Correction           Enabled
  
```

Type D to get a data string.

DATA STRING DESCRIPTION

12345678901234567890123456

U D Zdddd.d ssss.s ttttt<CR><LF>

WHERE:

U - UNITS (Depth and Tension)
 'E' - English, English, 'G' - English, Metric,
 'M' - Metric, Metric, 'F' - Metric, English
 D - DIRECTION ('U' - UP; 'D' - DOWN; 'S' - STOPPED)
 Z - ZERO DEPTH REF. ('+' BELOW GROUND; '-' ABOVE GROUND)
 d - DEPTH
 s - LINE SPEED
 t - TENSION
 <CR> - CARRIAGE RETURN, <LF> - LINEFEED

5.0 SPARE PARTS LIST

AMS4A063 PANEL WINCH OPERATOR DISPLAY PANEL

1	SW-623406	SOFTWARE FOR THE AMS4A062/6364	1	EA	
2	AMS4P134E	PC BOARD AMS40 REV E W/2xRS232	1	EA	
3	AMS7P080	METER DIFF TENSION	1	EA	
4	AMS7P081	METER TENSION POUND DUAL SCALE	1	EA	
5	AMS4P128	DISPLAY LED RED 0.5" 14 SEGMNT	3	EA	
6	ACMU1P06	LED RED DIALIGHT 5V	1	EA	METRIC
7	AMS4P211	SONALERT PS-580 MALLORY	1	EA	
8	AMS4P028	SWITCH DPDT TOGGLE LOCKING	1	EA	POWER
9	AMS4P020	SWITCH SPDT TOGGLE LOCKING	1	EA	METER HI/LO
10	AMS4P018	SWITCH SPDT PUSH MOM MPA-106F	4	EA	
11	AMS4P044	SWITCH DPDT TOGGLE MOM OFF MOM	1	EA	+ / -
12	AMS4P021	SWITCH CAP ALCO C-22 BLACK	4	EA	SHUNT, ZERO , MENU
13	AMS7P017	SWITCH CAP ALCO C-22 RED	1	EA	D-ZERO
23	AMS7P013	CONN MS3102E-18-9P LOAD CELL	1	EA	J4 - LOAD PIN INPUT
24	AMS4P264	CONN KPSE02E10-6S RECEPTACLE	1	EA	J7 - REMOTE DISPLAY
25	AMS7P068	SCREW JACK D-CONNECTOR KEYSTON	4	EA	
26	ACMU3P01	CONN MS3102E-14S-9P RECEPT	1	EA	J1 - POWER IN
27	ACMU3P02	CONN MS3102E-14S-9S RECEPT MAG	1	EA	J3 -OVER TENSION OUT
28	AMS4P164	CONN DB9S CRIMP AMP USED WITH	1	EA	J6 - RS232
29	ACMU2P06	CONN MS3102E-18-1P 10 PIN	1	EA	J2 - ENCODER IN
30	AMS4P198	SPACER UNTHREADED RND NYLON #4	12	EA	
31	AMS4M076	WINDOW LED RECESSED SERIAL	3	EA	
32	F244889000	HANDLE OVAL 1-1/2 X 3 AL	2	EA	
34	C276P165	FERRULE 18 AWG WHITE ALTECH	21	EA	
35	AMS4M063	PANEL FRONT SLICKLINE OP PNL	1	EA	
36	AMS4M168	PANEL REAR SLICKLINE W SIG OUT	1	EA	
37	AMS4M062	PANEL TOP WINCH OP SLICKLINE	1	EA	
38	AMS4M061	CHASSIS WINCH OP PNL SLICKLINE	1	EA	
39	AMS4P167	PIN AMP M39029/64-369 USED	9	EA	205089-1
40	AMS4A166	ASSY MEM CARD FCB COMP FLASH	1	EA	OPTION
41	AMS4M069	PLATE CVR MEM CARD SLOT SLICK	0	EA	OPTION
42	C276P152	LED GREEN DIALIGHT 12V	1	EA	ENGLISH
43	AMS4P041	SWITCH SPST PB NO MOM LIGHTED	1	EA	APPROACHING SURFACE
44	AMS4P042	LENS RED C&K SWITCH	1	EA	
45	AMS4P043	LED RED FOR C&K PUSHBUTTON SW	1	EA	1.90691.026
46	AMS4A102	PCB ASSY FUSE BOARD	1	EA	
47	C276P402	DIODE ZENER 6.8V 5W 1N5342B	1	EA	
50	AMS4P170	CONN KPSE02E12-10P RECEPTACLE	1	EA	J5 - ENCODER OUT
51	ALS1P029	CONN AMP BNC FRONT MOUNT	1	EA	J8 - TENSION OUT
53	AMS4A204	PCB ASSY IN CIRCUIT PROGRAMMG	1	EA	

6.0 CONNECTOR PINOUTS AND PANEL WIRING DIAGRAMS

6.1 BACK PANEL CONNECTOR PINOUT

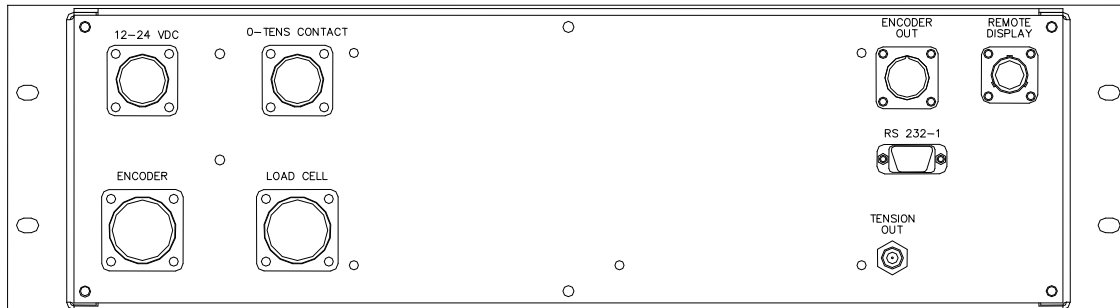

J1-A	12VDC POWER IN
J1-B	12VDC POWER GROUND
J2-A	ENCODER 1A
J2-B	ENCODER 1B
J2-D	ENCODER POWER (+12 VDC)
J2-F	ENCODER GROUND
J2-H	ENCODER 1A NOT
J2-I	ENCODER 1B NOT
J3-A	HOIST SHUTDOWN CONTACT CLOSURE
J3-B	HOIST SHUTDOWN CONTACT CLOSURE
J4-A	SIGNAL IN+
J4-B	LOAD PIN GROUND
J4-C	LOAD PIN EXCITE +
J4-E	SIGNAL IN -
J4-F	SHUNT CAL
J5-C & J5-J	ENCODER OUT GROUND
J5-D	ENCODER OUT PHASE A
J5-E	ENCODER OUT PHASE A\
J5-G	ENCODER OUT PHASE B
J5-H	ENCODER OUT PHASE B\

J6-2	COM1 RS232 TXD
J6-3	COM1 RS232 RXD
J6-5	GND
J7-GND	COMMON (BNC)
J7-CNTR	TENSION OUT (BNC) either 0-10vdc or 4-20ma
J8-A	12V POWER (SWITCHED)
J8-B	12V GROUND
J8-C	24V POWER TO REMOTE DISPLAY
J8-D	COM2 TXD
J8-E	PRESSURE SIG FROM REMOTE DISPLAY
J8-F	DIGITAL GROUND

6.2 INTERNAL PROCESSOR BOARD PINOUT

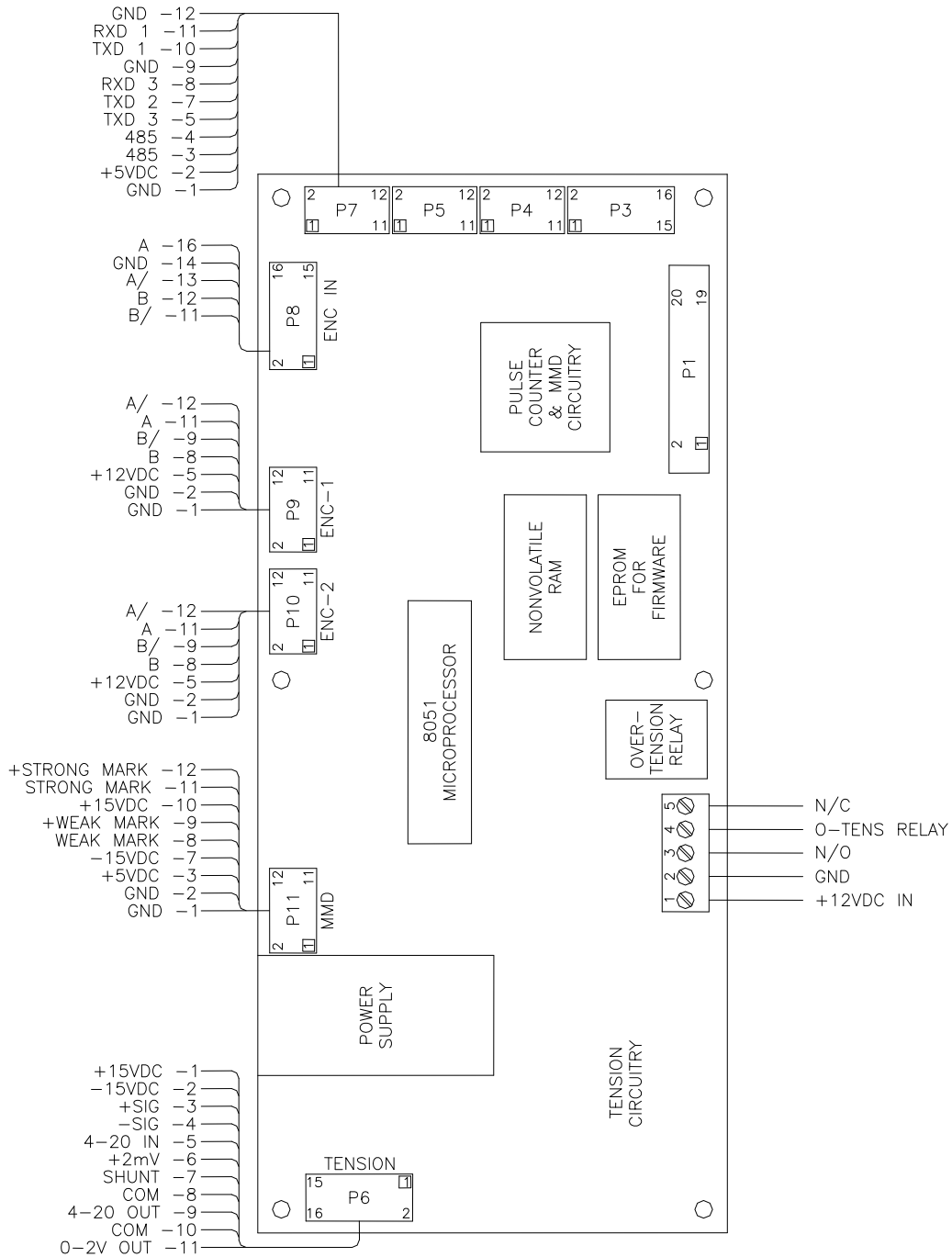

6.4 ENCODER OUTPUT AND COM PORT I/O

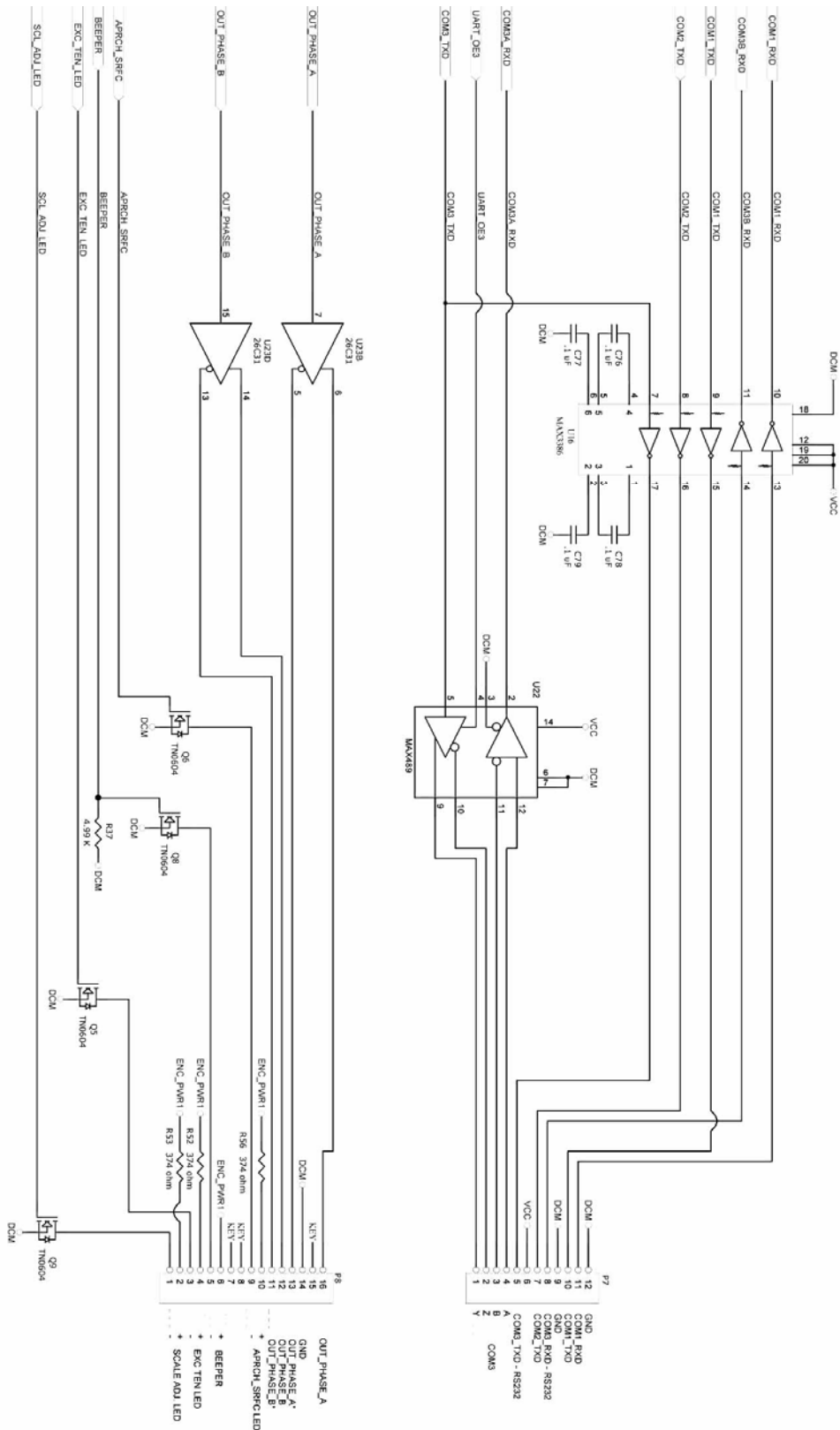

6.5 LOAD PIN AND TENSION I/O

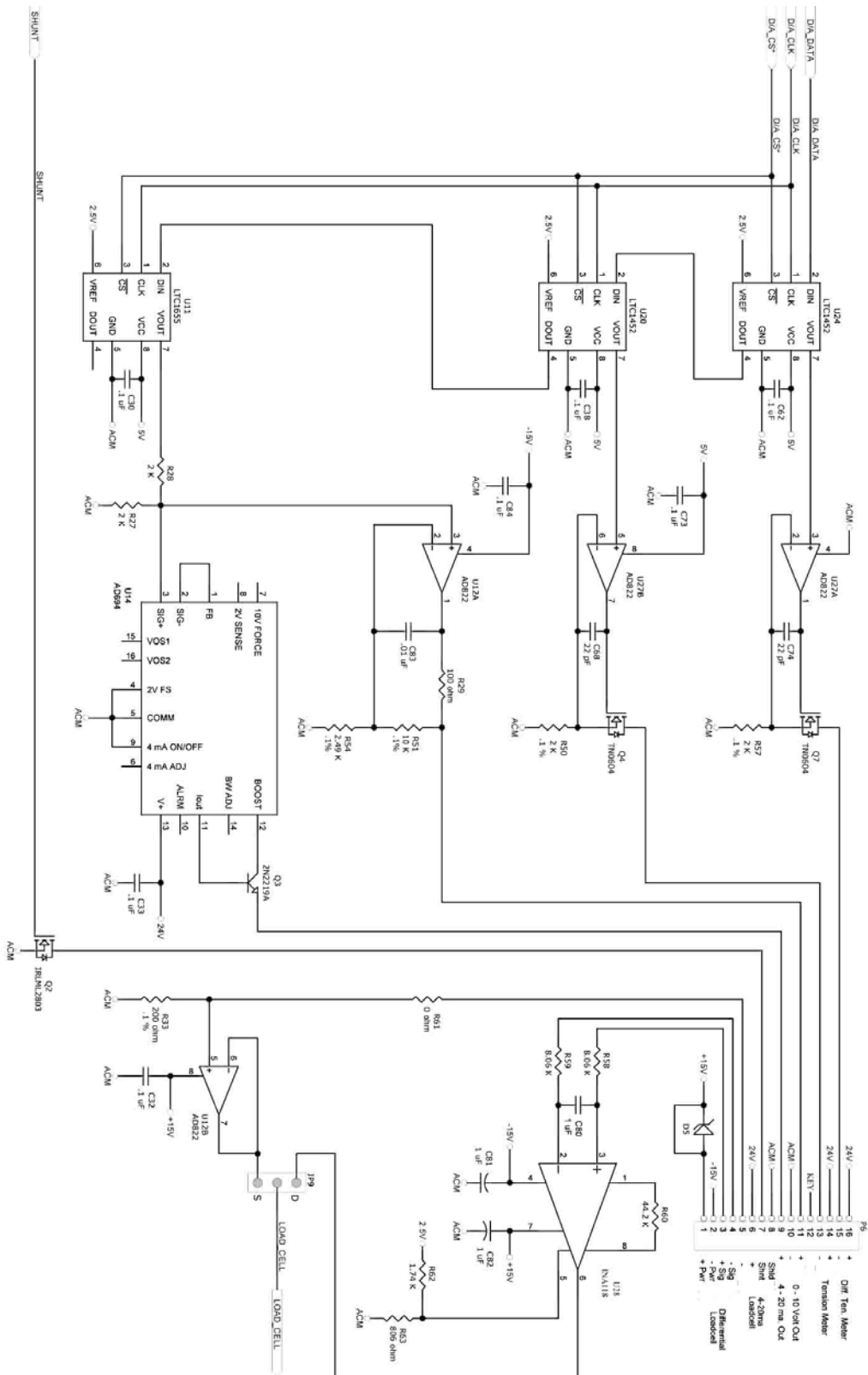

6.6 JUMPERS – BUTTONS

6.7 POWER SUPPLIES

6.8 PROCESSOR BOARD SETTINGS SOFTWARE CHANGES

Changes to the internal processor board are required in two instances. Changing software and changing depth and tension units between English and metric.

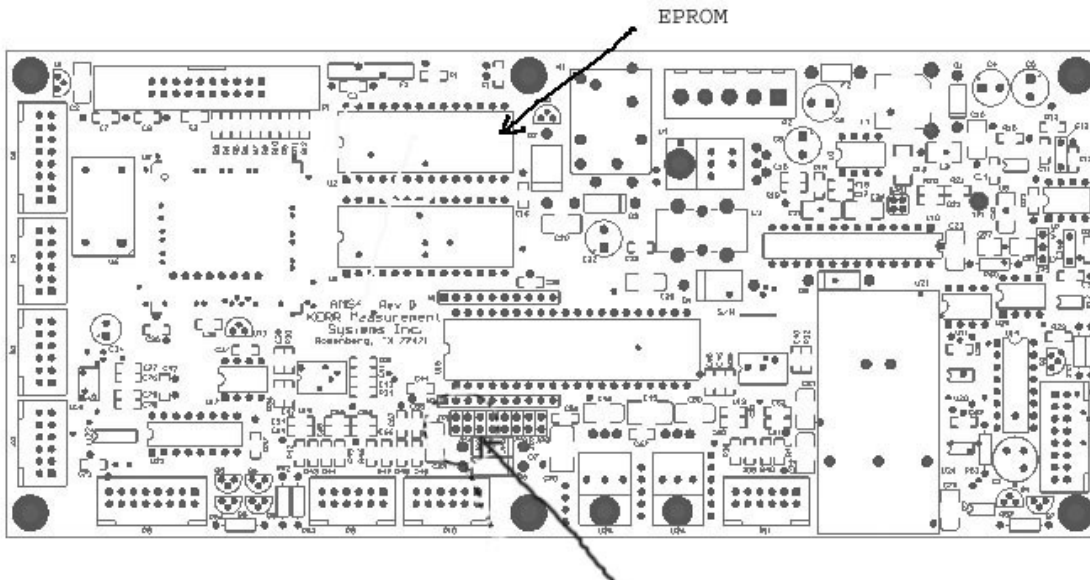

J4 ON = AMS4A063 PANEL
 J4 OFF = AMS4A062/64 PANEL

6.8.1 Software Modification

The software that controls this panel is stored in an EPROM Integrated Circuit located at U2 (see drawing on next page). To upgrade the software to a new version, simply remove the eprom I.C. and install a new eprom I.C. (be careful not to bend the legs during installation).

The software can also be modified by downloading a new file directly to the microprocessor using the serial port (refer to section 6.9).

6.8.2 PROCESSOR REBOOT

In the event of a panel "lock up" or other malfunction, the processor in the panel can be rebooted by turning off the panel, depressing the T-ZERO and T-CAL buttons simultaneously then turn the power back on while the buttons are depressed. Keep buttons depressed for at least five seconds after power is restored. When the panel is rebooted, all the menu settings will be returned to the default settings. The panel **MUST** always be rebooted after new software

has been installed.

6.8.3 TENSION VALUE SETUP FOR SHARK OR HAMMERHEAD

The two primary measuring heads this panel is configured for is the Shark (AMSLA102) and the HammerHead (AMSLA112)

One of the differences between these two heads is the tension range.

The Shark has a range of 0 – 4000 lbs.

The HammerHead has a range of 0 – 10000 lbs.

When Shark is selected from the menu (refer to section 3.12) 1.5vdc signal from the load pin is equal to 4000 lbs. When T-CAL button is depressed, the load pin will return a 1.5v signal and 4000 lbs should be displayed on the tension display.

When HammerHead is selected, a 1.5vdc signal from the load pin is equal to 10000 lbs. When T-CAL button is depressed, the load pin will return a .75v signal and 5000 lbs should be displayed on the tension display.

If 2000 is displayed on the tension display when T-CAL is depressed it is a good indication that the panel is set for Shark but connected to a HammerHead.

If 10000 lbs is displayed on the tension display when T-CAL is depressed it is a good indication that the panel is set for Hammerhead but connected to a Shark.

NOTE: The depth must be set to 0 to be able to read the T-CAL value from the load pin.

6.9 SOFTWARE MODIFICATION USING THE REAR SERIAL PORT

6.9.1 PREREQUISITES:

1. The real-time data acquisition board must have a socket for the MicroController and a CPU piggy-back PCB installed in that socket with a DS98C450 MicroController installed.
2. A PC with a serial port, and a terminal program such as Hyperterminal. Hyperterminal can usually be found under START - ALL PROGRAMS – ACCESSORIES - COMMUNICATIONS,
3. The new revision .HEX file program.

6.9.2 PROCEDURE:

1. Transfer the new revision HEX file to the PC to be used.
2. Turn power on to the Hoistman's panel.
3. Connect your PC to the serial port at the rear of the panel.
4. Open a Hyperterminal session.

Enter any name
Select one of the Icons
Select connect using – COM1

Use the following settings:

Serial Port: COM1
Baud Rate: 57600
Data Bits: 8
Parity: None
Stop Bits: 1
Flow Control: None

5. Set the switches on the CPU PCB to PROGRAM mode as follows:
 - 1 - AWAY FROM CPU
 - 2 - AWAY FROM CPU
 - 3 - TOWARD CPU
6. Open the Hyperterminal connection and then press the keyboard ENTER

3 - TOWARD CPU

13. REBOOT THE PANEL AT THIS TIME (refer to section 6.8.2)

6.10 DIGITAL DISPLAY SETUP

The three digital displays can be set for address, baud rate, and brightness

Two buttons are located on the rear of the display which are used to change these settings.



SELECT PARAMETER

INCREMENT UP

INCREMENT DOWN

The button nearest the connector selects the parameter (address, baud rate, brightness).

The center button increments the parameter up

The end button increments the parameter down.

After the parameter is set, press the parameter button again to store it.

The addresses should be set as follows:

Line Tension = 1

Line Speed = 2

Depth = 3

Set Baud Rate to 9600

Set Brightness to 15

Digital Display Pinout

PINS 1, 2, 7, 9	GND
PINS 4, 6, 8, 10	+5 VDC
PIN 3	TXD
PIN 5	RXD

6.11 PANEL WIRING DIAGRMS

J1	12 - 24 VDC IN
J2	ENCODER IN
J3	OVER TENSION OUT
J4	LOAD CELL IN
J5	ENCODER OUT
J6	RS232 SIGNAL
J7	REMOTE DISPLAY / PRESSURE
J8	TENSION OUT

P2 - Screw Terminal Block		MAIN PC BOARD		
P2 - 1	BATT +	RED	P1 - 7 (FUSE BRD), J7 - A	SWITCHED POWER
P2 - 2	BATT -	BLK - B	J1 - B, J7 - B	12 V GROUND
P2 - 3	CONTACT CLOSURE N.O.	GRN - B	J3 - A	Tension Contact Closure Back Panel
P2 - 5	CONTACT CLOSURE COM	BRN - A	J3 - B	Tension Contact Closure Back Panel
				Power Switch - When switch is up the 2 bottom pins should read together - up 0-red 0-red

P4 - USER SWITCHES				
P4 - 2	DCM BLK	BLK		FEET LED, SW4, SW2, SW6, SW5, SW9, SW7, SW8, SW10,
P4 - 5	HI / LO DIFF TEN RANGE	VIO	SW2 N.O.	RANGE SWITCH FOR DIFFERENTIAL TENSION
P4 - 6	METER RESET	GRY	SW4 N.O.	
P4 - 7	T CAL	GRN	SW5A - N.O.	SW5 (DPDT)
P4 - 8	T ZERO	BRN	SW6 N.O.	
P4 - 9	CANCEL DEPTH ALARM	BLU	SW10 N.O	
P4 - 10	ZERO DEPTH	YEL	SW9 N.O.	

P4 - 11	DEPTH ADJ DOWN (+)	WHT	SW7 N.O. DN	Dn Contact of SW7
P4 - 12	DEPTH ADJ UP (-)	ORN	SW7 N.O. UP	Up Contact of SW7

P5 - SPARE				
P5 - 1	+5V	RED	D1 - 4	DISPLAY POWER
P5 - 2	MENU	VIO	SW8 N.O.	MENU SELECT
P5 -12	DCM	BLK	D1 - 1	DISPLAY GND

P6 - ANALOG IN/OUT – AMS4A063 PANEL				
P6 - 3	LOAD PIN SIG+	RED	J4 - A	LOAD PIN SIGNAL+
P6 - 4	LOAD PIN SIG-	GRN	J4 - E	LOAD PIN SIGNAL-
P6 - 6	LOAD CELL 24V	BLU	J7 - C	24V TO PRESSURE TRANSDUCERS
P6 - 7	SHUNT CAL	GRN	J4 - F	SHUNT CAL
P6 - 8	ACM	BLK	J4 - B	LOAD PIN COMMON

P6 - ANALOG IN/OUT – AMS4A062 PANEL				
P6 – 1	LOAD PIN POWER +	P1 12 ENCDR BRD	LOAD PIN POWER	
P6 – 2	LOAD PIN POWER -	P1 11 ENCDR BRD	LOAD PIN POWER	
P6 – 3	LOAD PIN SIG+	J3 E	LOAD PIN SIGNAL+	
P6 – 4	LOAD PIN SIG-	J3 F	LOAD PIN SIGNAL-	
P6 – 7	SHUNT CAL ENABLE	J3 G	SHUNT CAL	
P6 – 8	ACM	J3 D	LOAD PIN COMMON	

P6 - ANALOG IN/OUT - AMS4A064 PANEL				
P6 - 5	4to20IN	J4 - D	4 TO 20 TESNION SIGNAL	
P6 - 6	LOAD CELL 24V	P1-10, P1-3 FUS BRD	2 WIRES, 4 TO 20 MA POWER & REMOTE 24V	

P6 - 7	SHUNT CAL ENABLE	J4-E	SHUNT CAL	
P6 - 8	ACM	J4-B	GND	P6 - 8
P6 - 9	4to20OUT	BRN	J8 - N/C	TIE WIRE NEAR J8 BUT DO NOT CONNECT
P6 - 10	ACM	BLK	J8 - GND	TENSION OUT GROUND
P6 - 11	0-10V OUT (TENSION)	BLU	J8 - CENTER	TENSION OUT
P6 -13	TENSION METER-	VIO	M2-	
P6 -14	TENSION METER+	ORN	M2+	
P6 - 15	DIFF TENSION METER -	YEL	M1 -	
P6 - 16	DIFF TENSION METER +	BLU	M1 +	

P7 - COMMUNICATIONS				
P7 - 1	RS485 TX+	GRY	J7	
P7 - 2	RS485 TX-	BLK	J7	
P7 - 3	RS485RX-	GRN	J7	
P7 - 4	RS485RX+	BLU	J7	
P7 - 5	COM3 TXD	GRN	CARD READER DATA PORT J1 - 2	
P7 - 6	5V ENCDR PWR - FUSE BRD	YEL	P1 - 2 FUSE PCB	FUSE BOARD P1-2
P7 - 7	COM2 TXD	ORN	D1 - 5, D2 - 5, D3 - 5, J7 - D	DISPLAY DATA - THREE WIRES CONNECTED TOGETHER
P7 - 8	COM3 RXD	WHT	J7 - E	PRESSURE SIGNAL IN FROM REMOTE DISPLAY
P7 - 9	GND	BLK	CARD READER DATA PORT J1 - 3	RS485 GND (2 WIRES)
P7 -10	COM1 TXD	BRN	J6 - 2	RS232 TRANSMIT
P7 - 11	COM1 RXD	WHT	J6 - 3	RS232 RECEIVE
P7 - 12	GND	BLK	J6 - 5	RS232 GND

P8 - QUADRATURE OUT / INDICATORS				
P8 - 1	METRIC LED	BRN		METRIC LED CATHODE (-)
P8 - 2	ENC_PWR1	ORN	METRIC LED+ & 6.8VZ Cathode	METRIC LED ANODE & 6.8VZ Cathode 6.8VZ Anode to ENGLISH LED +
P8 - 5	BEEPER	GRN Beeper	ALM1 -	BEEPER
P8 - 6	ENC_PWR1	YEL	ALM1 +	BEEPER
P8 - 9	APPROACHING SURF	VIO	SW10	APPROACHIN SURF LED- +1 (inline with silver plate)
P8 - 10	ENC_PWR1	BLU	SW10	APPROACHING SURFACE LED+ -1 (OPPOSITE with silver plate)
P8 - 11	PHASE 1B\	WHT	J5 - H	ENCODER OUT
P8 - 12	PHASE 1B	GRY	J5 - G	ENCODER OUT
P8 - 13	PHASE 1A\	ORN	J5 - E	ENCODER OUT
P8 - 16	PHASE 1A	BRN	J5 - D	ENCODER OUT

P9 - ENCODER 1				
P9 - 1	DCM	BLK	J2 - F	Encoder Ground
P9 - 2	DCM	BLK	J5 - J, J5 - C, J7 - F	DIGITAL GROUND (Encoder + RS232)
P9 - 5	ENCODER PWR - TO FUSE	YEL	P1 -10 FUSE PCB	
P9 - 8	ENCODER 1B	BLU	J2 - B	Encoder input
P9 - 9	ENCODER 1B \	GRN	J2 - I	Encoder input
P9 - 11	ENCODER 1A	ORN	J2 - A	Encoder input
P9 - 12	ENCODER 1A\	RED	J2 - H	Encoder input

P10 - ENCODER 2				
P10 - 1		BLK	CARD READER J3 - 1	GND
P10 - 5		WHT	CARD READER J3 - 2	+12VDC

D1 DISPLAY - DEPTH				
D1 - 2	GND	BLK	D2 - 1	GND
D1 - 6	+5V OUT	RED	D2 - 4	POWER OUT

D2 DISPLAY - LINE SPEED				
D2 - 2	GND	BLK	D3 - 1	GND
D2 - 6	+5V OUT	RED	D3 - 4	+5V OUT

POWER SWITCH				
SW1A - NO	MAIN POWER ON/OFF	RED	J1 - A	
SW1A - C	WIPER TO FUSE BOARD	RED	FUSE PCB P1 - 1	

FUSE BOARD				
P1 - 4	ENCODER1 PWR FUSED	YEL	J2 - D	FUSED LOAD CELL POWER OUT (24V)
P1 - 12	12VDC (FUSED)	RED	J4 - C, SW5B - COM	LOAD PIN EXCITATION

SWITCH 5 (DPDT PUSH BUTTON)				
SW5B - NO	12 VDC POWER (FUSED)	RED	J4 - G	SHUNT CAL (12 VDC)

J2 - CARD READER				
J2 - 1		BRN	DB9F - 2 ON THE FRONT PANEL	RS232 RX
J2 - 2		WHT	DB9F - 3 ON THE FRONT PANEL	RS232 TX
J2 - 3		BLK	DB9F - 5 ON THE FRONT PANEL	GND

7.0 CABLE DRAWINGS AND PARTS LISTS

7.1 AMS7A022 CABLE ASSEMBLY – DC POWER IN

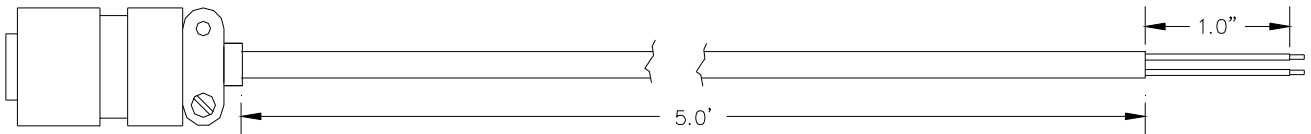

A – WHITE
 B – BLACK

A = +
 B = -

P/N	Description	Qty
AMS7P061	CABLE 16-2 SJ CORD BELDEN 8472	5 FT
AMS7P044	CONN MS3106E-14S-9S	1 EA
AMS7P063	BUSHING #9779-513-6 AMPHENOL	1 EA

7.2 AMS7A023 CABLE ASSEMBLY – OT SHUTDOWN

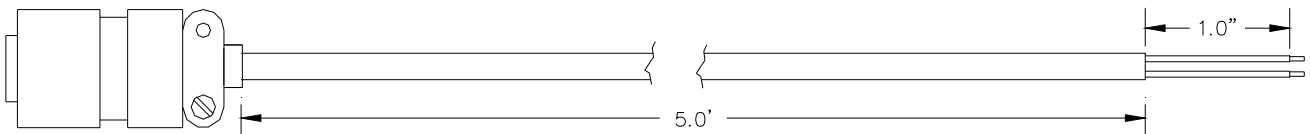

P/N	Description	Qty
AMS7P061	CABLE 16-2 SJ CORD BELDEN 8472	5 FT
AMS7P045	CONN MS3106E-14S-9P	1 EA
AMS7P063	BUSHING #9779-513-6 AMPHENOL	1 EA

7.3 AMS4A353 2mv / v CABLE ASSEMBLY – LOAD PIN

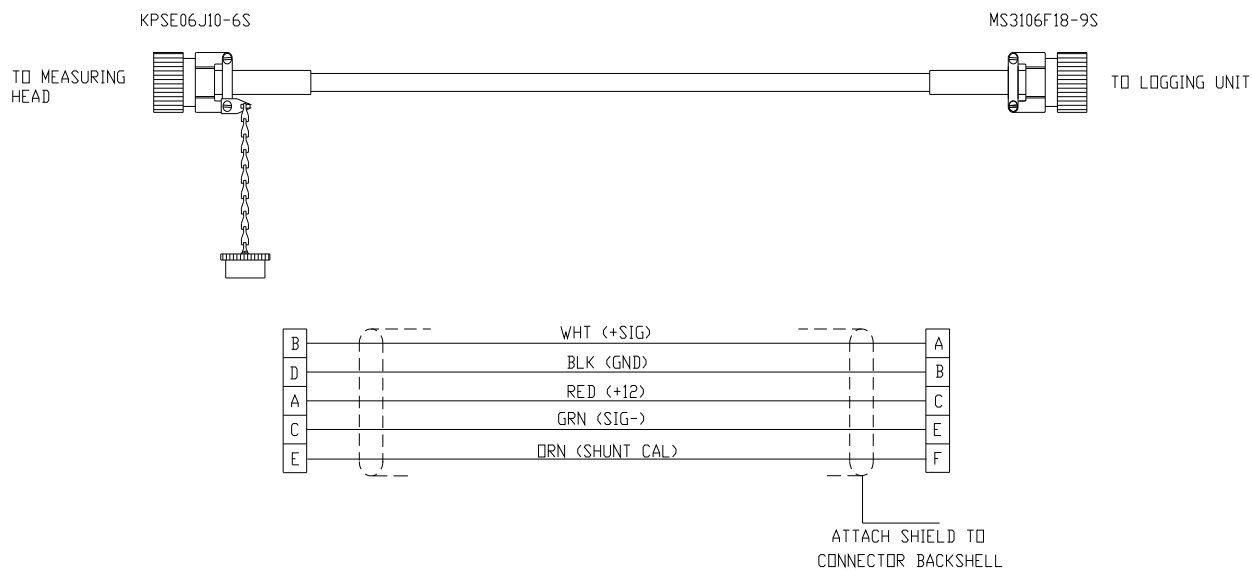

P/N	Description	Qty	
AMS4P266	CONN KPSE06J10-6S STR PLUG	1	EA
AMS7P014	CONN MS3106F-18-9S LOAD CELL	1	EA
AMS4P221	CABLE 20/8C ALPHA 25468 BLACK	20	FT
AMS4P209	TUBING SHRINK 0.75 ADH LINED	1	IN
AM5KP059	DUST CAP KPT8010C CANNON	1	EA
AMS7P063	BUSHING #9779-513-6 AMPHENOL	1	EA
ACMU1P89	TUBING SHRINK 1.50 ADH LINED	1	EA
C276P318	TERMINAL #RA18-6 #6 RING	1	EA

7.4 AMS8A024 1.5v DIFFERENTIAL TENSION CABLE ASSEMBLY – LOAD PIN



P/N	Description	Qty	Ref
AMS4P221	CABLE 20/8C ALPHA 25468 BLACK SHIELDED	20 FT	
AMS8P057	CONN KPT06A16-8S STR PLUG	1 EA	PIN END
AMS7P014	CONN MS3106E-18-9S LOAD PIN	1 EA	PNL END
AMS8P060	DUST CAP CANNON SHELL SIZE 16	1 EA	

7.5 AMS7A031 4-20MA CABLE ASSEMBLY – LOAD PIN

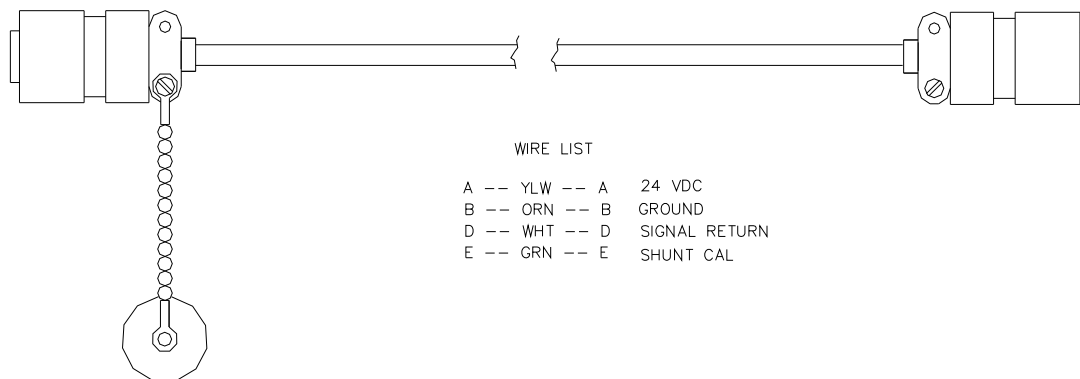

P/N	Description	Qty	
AMS7P014	CONN MS3106F-18-9S LOAD CELL	2	EA
AMS1P029	DUST CAP MS25042-18DA	1	EA
AMS7P063	BUSHING #9779-513-6 AMPHENOL	4	EA
AMS7P064	BUSHING #9779-513-8 AMPHENOL	2	EA
ACMU2P23	BUSHING #9779-513-10 AMPHENOL	2	EA
AMS4P221	CABLE 20/8C ALPHA 25468 BLACK	20	FT

7.6 AMS4A125 CABLE ASSEMBLY - ENCODER

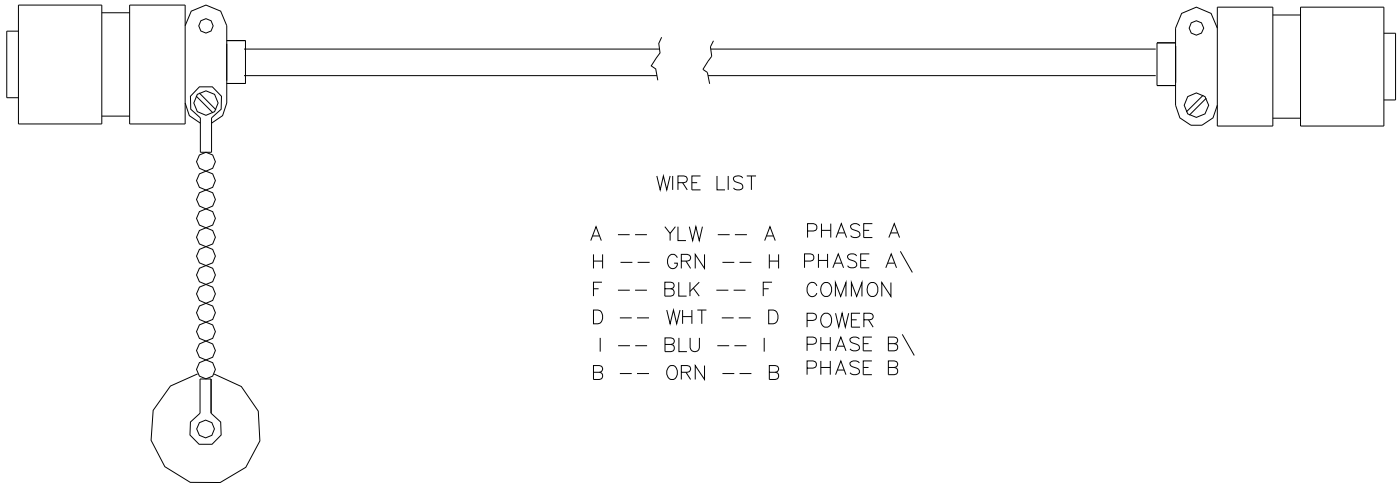

P/N	Description	Qty
AMS1P028	CONN MS3106E-18-1S	2 EA
AMS1P029	DUST CAP MS25042-18DA	1 EA
AMS4P221	CABLE 20/8C ALPHA 25468 BLACK SHIELDED	20 FT

7.7 AMS7A024 CABLE ASSEMBLY – RS232

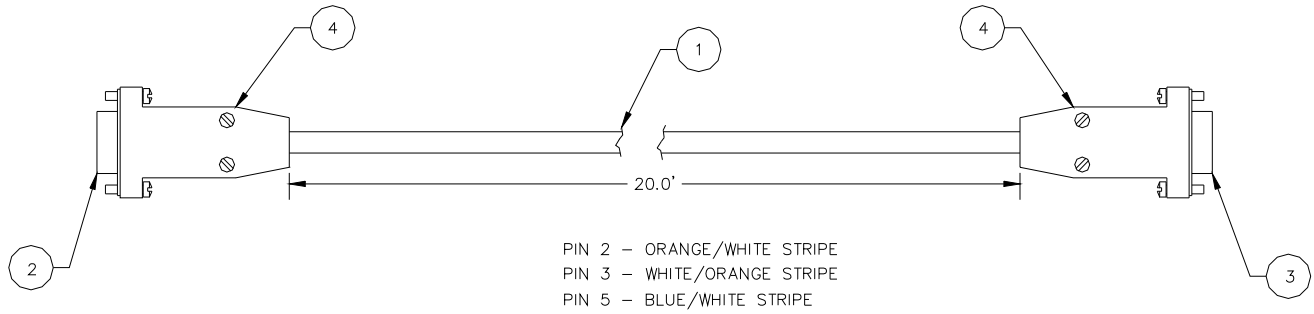

PIN 2 – TXD
 PIN 3 – RXD
 PIN 5 - GND

P/N	Description	Qty
AMS7P062	CABLE 24/2P STNDED PE/PVC	20 FT
AMS7P016	CONN DE-9P	1 EA
AMS7P015	CONN DE-9S	1 EA
AMS7P067	CONNECTOR AMP CABLE CLAMP	2 EA